

SPECIFICATIONS

GENERAL:

The surface drainage system shall be FoodSafe Area Drain - Round, complete with catch basin, as manufactured by Food Safe Drains.

MATERIALS:

T304 Stainless Steel or T316 Stainless Steel

LOAD CLASS:

Load Class E - Forklift Rated

INSTALLATION:

The FoodSafe Area Drain - Round shall be installed in accordance with the manufacturer's installation instructions and recommendations.

TYPICAL PROFILE OF A FOOD SAFE AREA DRAIN - CONE SYSTEM

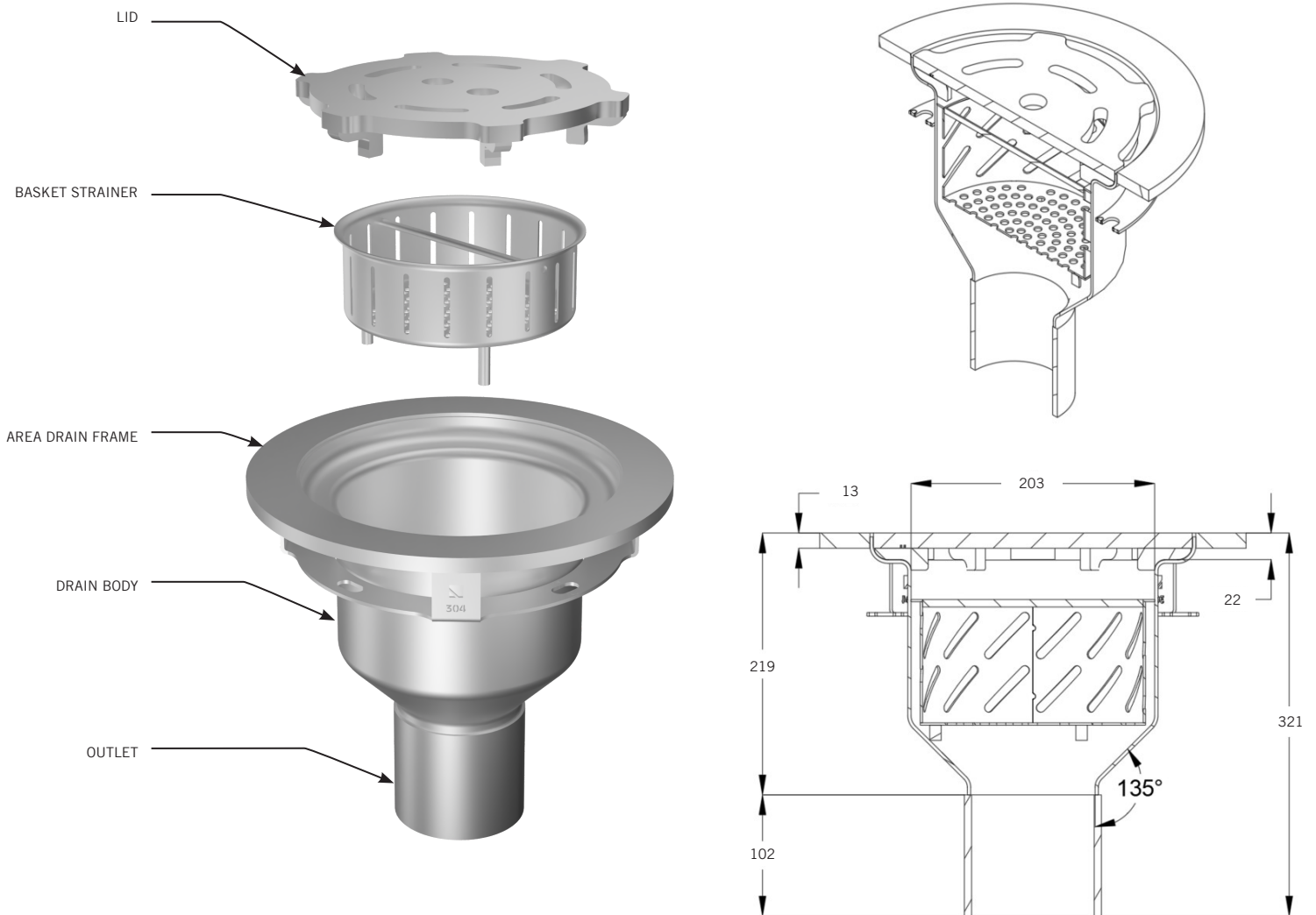

MEASUREMENTS

DESCRIPTION	DRAIN TOP ID MM	DRAIN OD MM	LID DIAMETER MM	LID HEIGHT MM	OUTLET DIAMETER MM	OUTER EDGE MM
FSD AREA - CONE	203	267	235	13	102	356

OPTIONALLY, MAGLOCK DESIGN ALSO AVAILABLE.
SPECIFYING ENGINEER IS RESPONSIBLE FOR CONCRETE ENCASUREMENT AND REINFORCING BASED UPON APPLICATION AND LOCAL CODES.
FOODSAFE DRAINS RESERVES THE RIGHT TO CHANGE THE PRODUCT AND SPECIFICATIONS WITHOUT NOTICE