

SPECIFICATIONS

GENERAL:

The surface drainage system shall be Food Safe Area Drain - Round, complete with strainer basket, as manufactured by FoodSafe Drains.

MATERIALS:

T304 Stainless Steel or T316 Stainless Steel

LOAD CLASS:

Load Class E - Forklift Rated

INSTALLATION:

The Food Safe Area Drain - Round shall be installed in accordance with the manufacturer's installation instructions and recommendations.

TYPICAL PROFILE OF A FOOD SAFE AREA DRAIN - ROUND SYSTEM

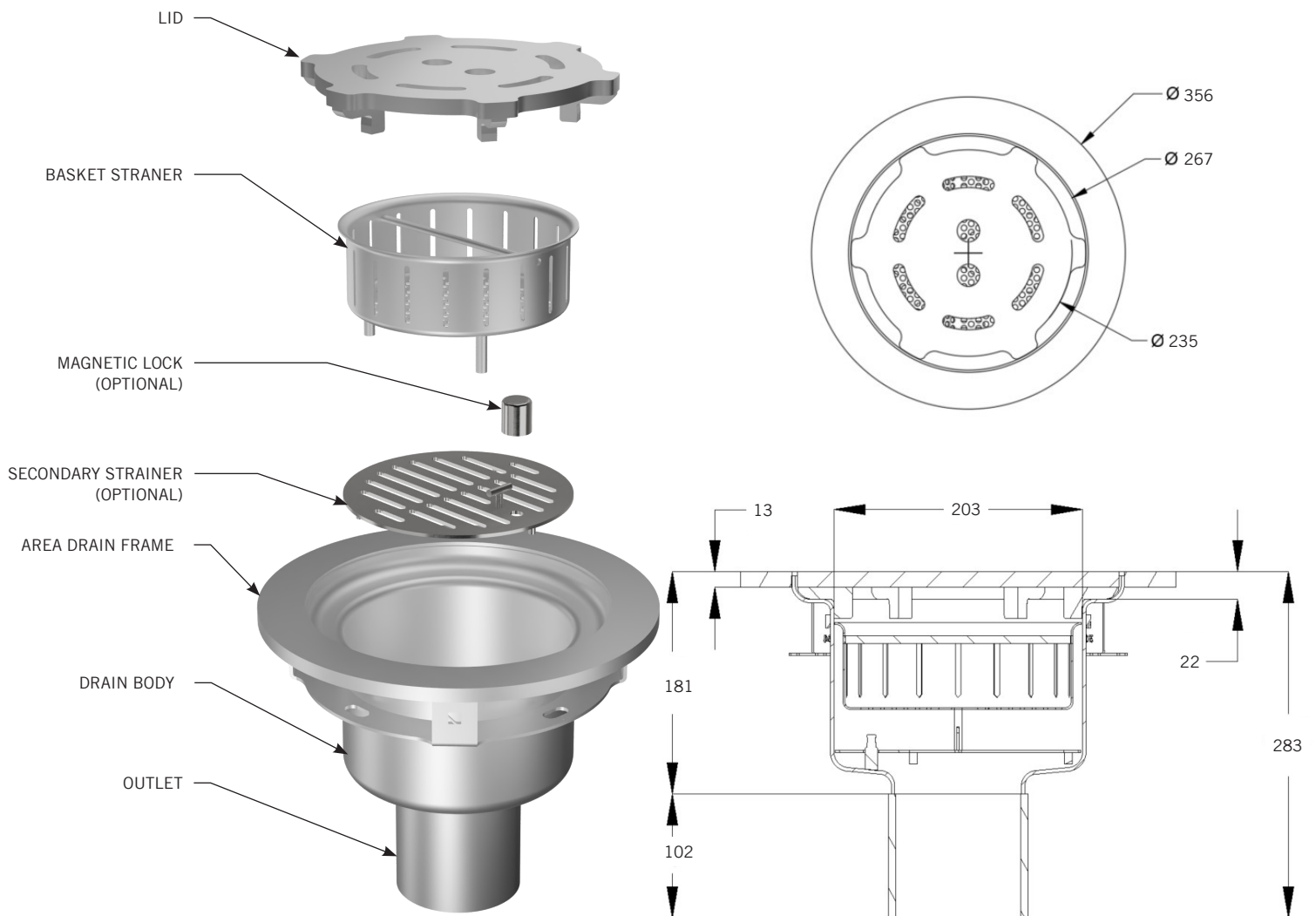

MEASUREMENTS

DESCRIPTION	DRAIN TOP ID MM	DRAIN OD MM	LID DIAMETER MM	LID HEIGHT MM	OUTLET DIAMETER MM	OUTER EDGE MM
FSD AREA - ROUND	203	267	235	13	102	356

OPTIONALLY, NON-MAGLOCK DESIGN ALSO AVAILABLE.
SPECIFYING ENGINEER IS RESPONSIBLE FOR CONCRETE ENCASEMENT AND REINFORCING BASED UPON APPLICATION AND LOCAL CODES.
GLOBAL DRAIN TECHNOLOGIES RESERVES THE RIGHT TO CHANGE THE PRODUCT AND SPECIFICATIONS WITHOUT NOTICE.